

EFFECTS OF GROUND-WATER DEVELOPMENT
IN THE WILDER AREA,
SOUTHWEST CANYON COUNTY, IDAHO

by
Steven J. Baker

Idaho Department of Water Resources
Boise, Idaho

November, 1991

TABLE OF CONTENTS

INTRODUCTION	1
Statement of Problem	1
Well-numbering system	2
HYDROGEOLOGIC REGIME	3
Occurrence and Movement of Ground Water	3
Short-Term Well Interference	5
Relationship Between Recharge and Discharge	6
CONCLUSIONS	12

LIST OF FIGURES

Figure 1. Location of study area	1
Figure 2. Well-numbering system	2
Figure 3. Elevation of potentiometric surface, March 1980	4
Figure 4. Drawdown distribution for simulation #1	7
Figure 5. Drawdown distribution for simulation #2	9
Figure 6. Drawdown difference between simulations #1 and #2	9
Figure 7. Hydrographs of well 04N-05W-07DCD1 and Deer Flat Low-Line Canal	11

LIST OF TABLES

Table 1. Records of selected wells	3
Table 2. Drawdowns from pumping well 04N-05W-10DDC1	5
Table 3. Parameters used in well interference simulations	10

INTRODUCTION

Statement of Problem

Well owners located near Wilder (see Figure 1) are currently protesting an application for a new irrigation well. They are concerned over its potential impact on their domestic wells. In order to assess the what effects the protested well would have on the local aquifer system, a pumping test of this well was conducted. The results from this test were analyzed and used to estimate the effects of short-term well interference in the area. Historic water-level trends in the area were used to evaluate the current relationship between recharge and discharge in the area.

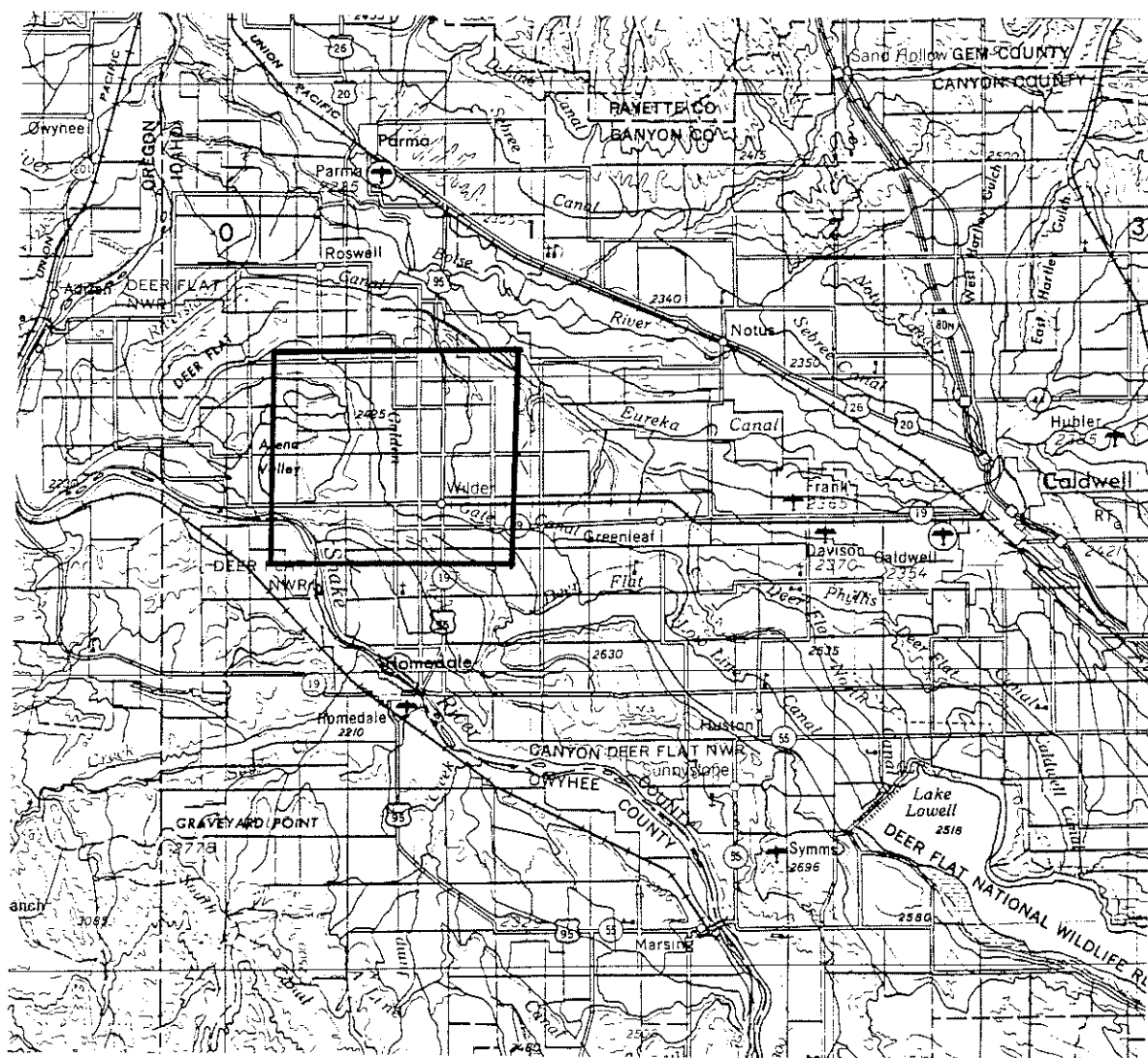

Figure 1. Location of study area

Well-numbering system

The well-numbering system used in this report is identical to the system that is used by the U.S. Geological Survey (USGS) in Idaho. The system indicates the location of wells within the official rectangular subdivision of the public lands, with reference to the Boise base line and meridian. The first two segments of the number designate the township and range. The third segment gives the section number, followed by three letters and a number, which indicate the $\frac{1}{4}$ section (160-acre tract), $\frac{1}{4}-\frac{1}{4}$ section (40-acre tract), $\frac{1}{4}-\frac{1}{4}-\frac{1}{4}$ section (10 acre tract), and serial number of the well within the tract. Quarter sections are lettered A, B, C, and D in counterclockwise order from the northeast of each section. Within quarter sections, 40-acre and 10-acre tracts are lettered in the same manner. For instance, well 12S-22E-16CCC1 corresponds to the legal location SW $\frac{1}{4}$, SW $\frac{1}{4}$, SW $\frac{1}{4}$, Section 16, Township 12 South, Range 22 East, and was the first well inventoried in that tract (see Figure 2).

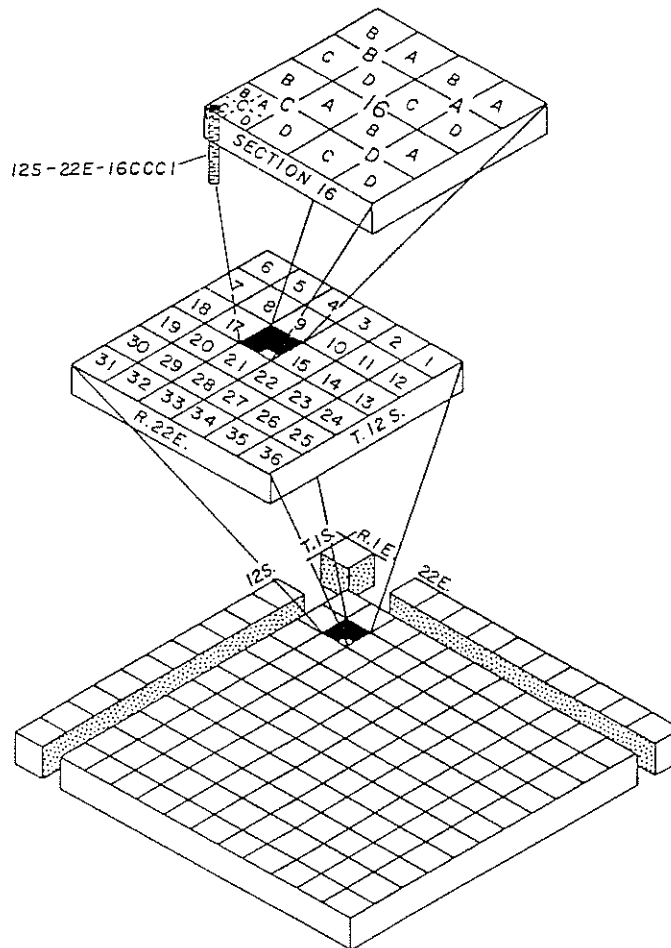

Figure 2. Well-numbering system

HYDROGEOLOGIC REGIME

Occurrence and Movement of Ground Water

Ground water in the area occurs within the fluvial and lacustrine sediments of the Glenns Ferry Formation. The sediments are composed of alternating layers of sand and clay with lesser amounts of gravel. Clay layers appear to become thicker and more numerous at progressively greater depths. According to the Well Driller's Report for well 04N-05W-10DDC1, the most permeable portion of the aquifer system occurs at depths shallower than 400 ft.

Recharge to the aquifer in the area occurs primarily through infiltration from unconsumed irrigation water. Natural discharge from the aquifer occurs as underflow leaving the area to the west and southwest. Some of the underflow leaving the immediate area discharges to the Snake River and contributes to its base flow. Artificial discharge occurs through pumpage from wells.

Based on water-level measurements taken in March 1980, the elevation of the potentiometric surface of the aquifer was constructed for the area and is shown on Figure 3. Pertinent information about the wells used to create this map are included in Table 1. The direction of ground-water movement in the area is from east to west, except in the southwest portion, where it flows southwesterly towards the Snake River. The slope of the potentiometric surface in the area ranges from 16 to 60 ft per mile. The gentle gradient over most of the area probably reflects the regional effects of recharge from unconsumed irrigation water.

Table 1. Records of selected wells

Elevation of LSD: or land surface datum estimated from USGS topographic maps and field surveys. Use of water: H - Domestic; I - Irrigation; P - Public Supply; S - Stock. Depth to water: measured by USGS in feet below land surface.

Well number	Elevation of LSD (ft)	Use of water	Well depth (ft)	Depth to first well opening (ft)	Depth to water (ft)	Date measured
04N-05W-07DCD1	2292	I	131	64	16.1	03/14/80
10CDD1	2423	H/S	306	287	71.5	03/14/80
12CBC1	2415	H/S	29	--	17.1	03/14/80
22CCC1	2291	H/S	101	--	14.2	03/26/80
23BCC1	2465	P	525	285	103.0	03/26/80
05N-05W-32CDC1	2312	H/S	58	57	26.0	11/05/81

SOUTHWEST CANYON COUNTY

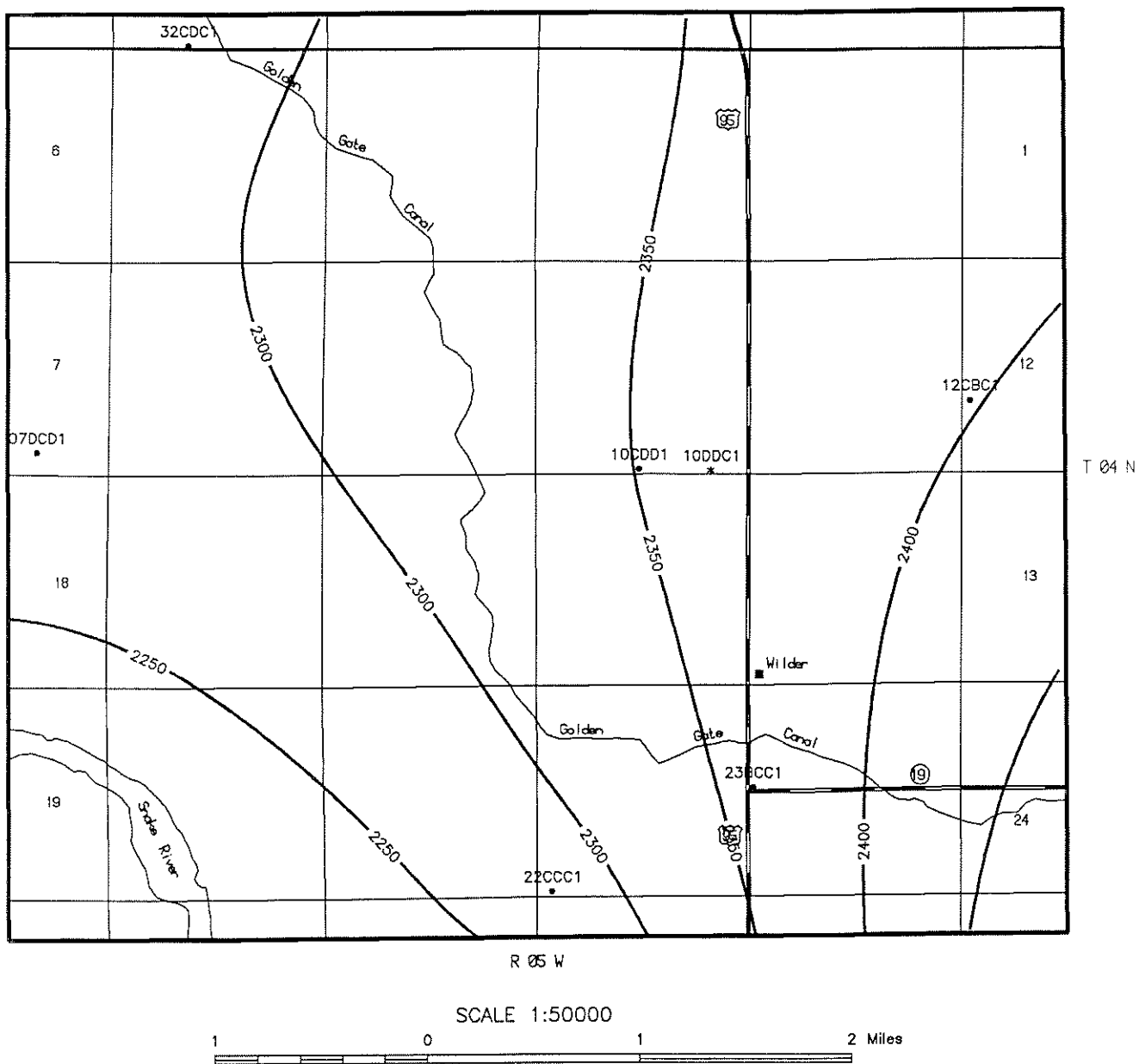

Figure 3. ELEVATION OF POTENTIOMETRIC SURFACE, MARCH 1980

Short-Term Well Interference

On August 7, 1991, a 28-day aquifer test was initiated at well 04N-05W-10DDC1 in order to determine the effects of pumping this well on the local aquifer system. The well was pumped continuously during the test at an average rate of 1739 gallons per minute (gpm). Drawdown was measured in the pumping well along with two nearby domestic wells (04N-05W-15AAA1 and 04N-05W-15ABA1). A listing of the observed drawdowns in the wells at the end of the pumping is shown on Table 2.

Table 2. Drawdowns from pumping well 04N-05W-10DDC1

Well Number	Distance from pumping well (ft)	Drawdown after 28 days of pumping (ft)
04N-05W-10DDC1	--	144
15AAA1	800	25
15ABA1	1100	28

Hydraulic properties of the aquifer system were estimated from test results using the modified version of the Theis non-equilibrium formula. The computed values for transmissivity (T) range from about 4900 to 8500 ft²/day. These values compare well with T values estimated from specific capacity data acquired from the Well Driller's Reports for the pumping well. The computed values for storativity (S) from the test data range from 2.0 x 10⁻⁴ to 9.3 x 10⁻⁴. For comparison, a value for S estimated from a method using aquifer thickness also falls within this range of S values.

Utilizing the results acquired from the aquifer test, a hypothetical analysis of local well interference in the area was performed. Mean values for the hydraulic properties were used in the analysis. The average T value for the three wells equals to 6200 ft²/day and the average S value for the two observation wells equals to 5.6 x 10⁻⁴. As a way of assessing the individual and cumulative effects of pumping well 04N-05W-10DDC1 on the local aquifer system, two simulations were performed and then compared with each other. Both simulations entailed computing the estimated drawdown at the end of a 150-day irrigation season. The first simulation involved estimating the drawdown configuration produced by pumping all non-domestic wells within a 1-½ mile radius from domestic wells 04N-05W-15AAA1 and 04N-05W-15ABA1, except for well 04N-05W-10DDC1. Whereas, the second simulation included all these wells along with well 04N-05W-10DDC1. The difference between these two simulations was used to determine the individual effect on the local aquifer system from pumping well 04N-05W-10DDC1.

The maps included on Figures 4, 5, and 6 show the distribution of drawdown for each of these three cases, respectively. A list of the wells used in the simulations including their average discharge rates are presented on Table 3. Locations of the wells are shown on the figures.

As these figures illustrate, the cones of depression produced by the pumping wells in the area are very pronounced and extend great distances. This is due to the relatively low hydraulic properties that were computed for the local aquifer system. For simulation #1, computed drawdown in the vicinity of the domestic wells 04N-05W-15AAA1 and 04N-05W-15ABA1 approaches 45 ft. With the pumping of well 04N-05W-10DDC1 included, simulation #2 indicates computed drawdown of over 75 ft in this same area. Based on the difference in drawdown between these two simulations, the individual effect of pumping well 04N-05W-10DDC1 is estimated to be over 30 ft of drawdown in this area at the end of a 150-day irrigation season.

Relationship Between Recharge and Discharge

Changes in the amount of ground water held in storage are the result of the dynamic relationship between recharge and discharge in the area. These changes are reflected in the annual and long-term fluctuations in the potentiometric surface and are illustrated by the hydrograph of well 04N-05W-07DCD1 included on Figure 7. In order to show the effects of recharge from irrigation water on the observed water-level trends, a hydrograph of the annual volume of water diverted from Lake Lowell into the Deer Flat Low-Line Canal was also included on Figure 7. This canal provides water to the Golden Gate Canal that traverses the study area (see Figure 3).

Seasonal fluctuations in water levels for this well are strongly dominated by the effects of artificial recharge from unconsumed irrigation water. Water levels are at their highest in late summer and lowest in early spring. Magnitudes of seasonal fluctuations are generally about 2 to 4 ft. Long-term trends in water levels for this well appear to roughly follow annual variations in the amount of surface water diversions. During periods of below normal surface water supplies, increased pumpage probably accentuates the observed declines in the potentiometric surface. The difference between annual extremes for the 21-year period of record is only about 8 ft and suggests that recharge and discharge have remained relatively constant in the area.

SOUTHWEST CANYON COUNTY

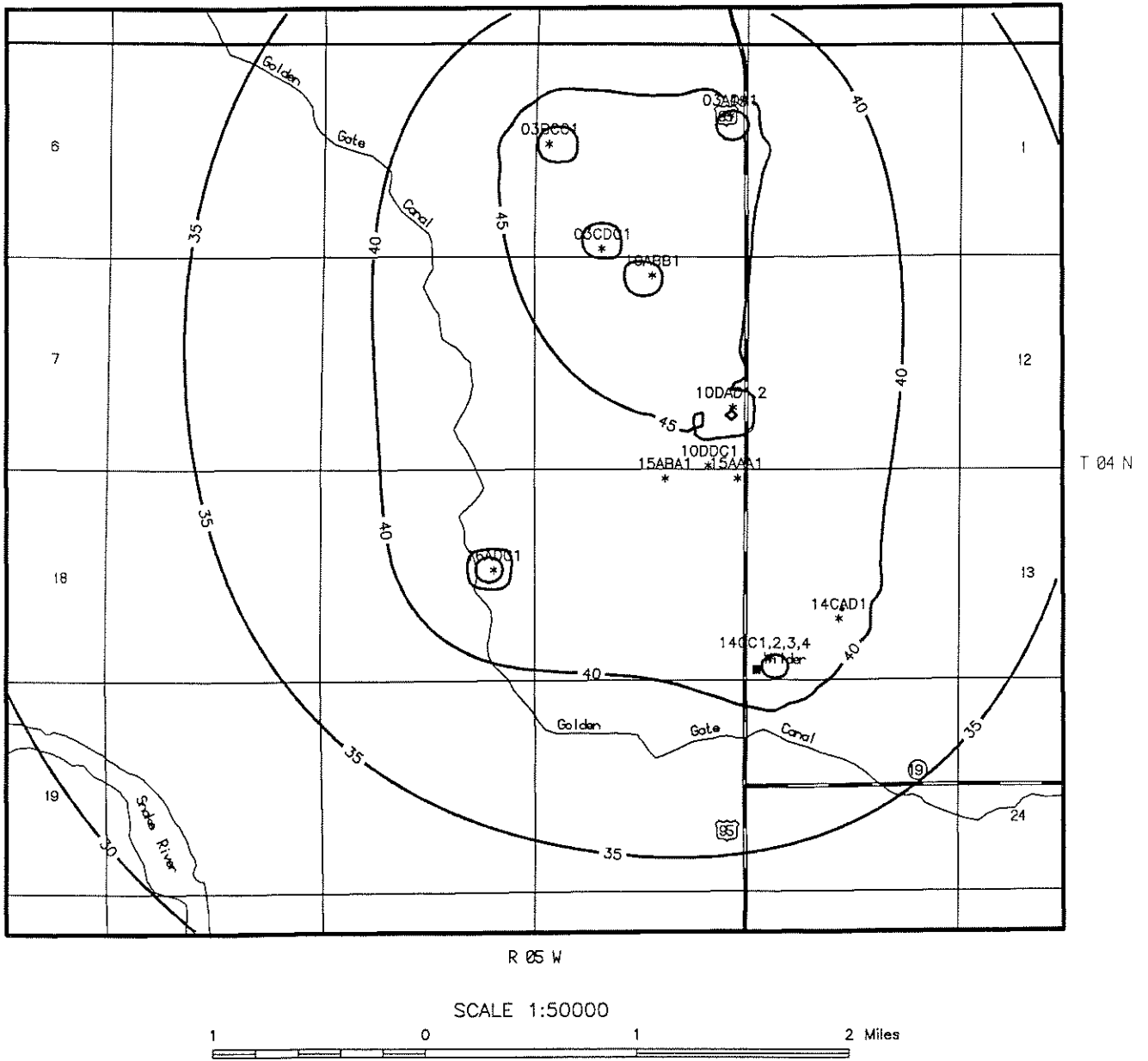

Figure 4. DRAWDOWN DISTRIBUTION FOR SIMULATION #1

SOUTHWEST CANYON COUNTY

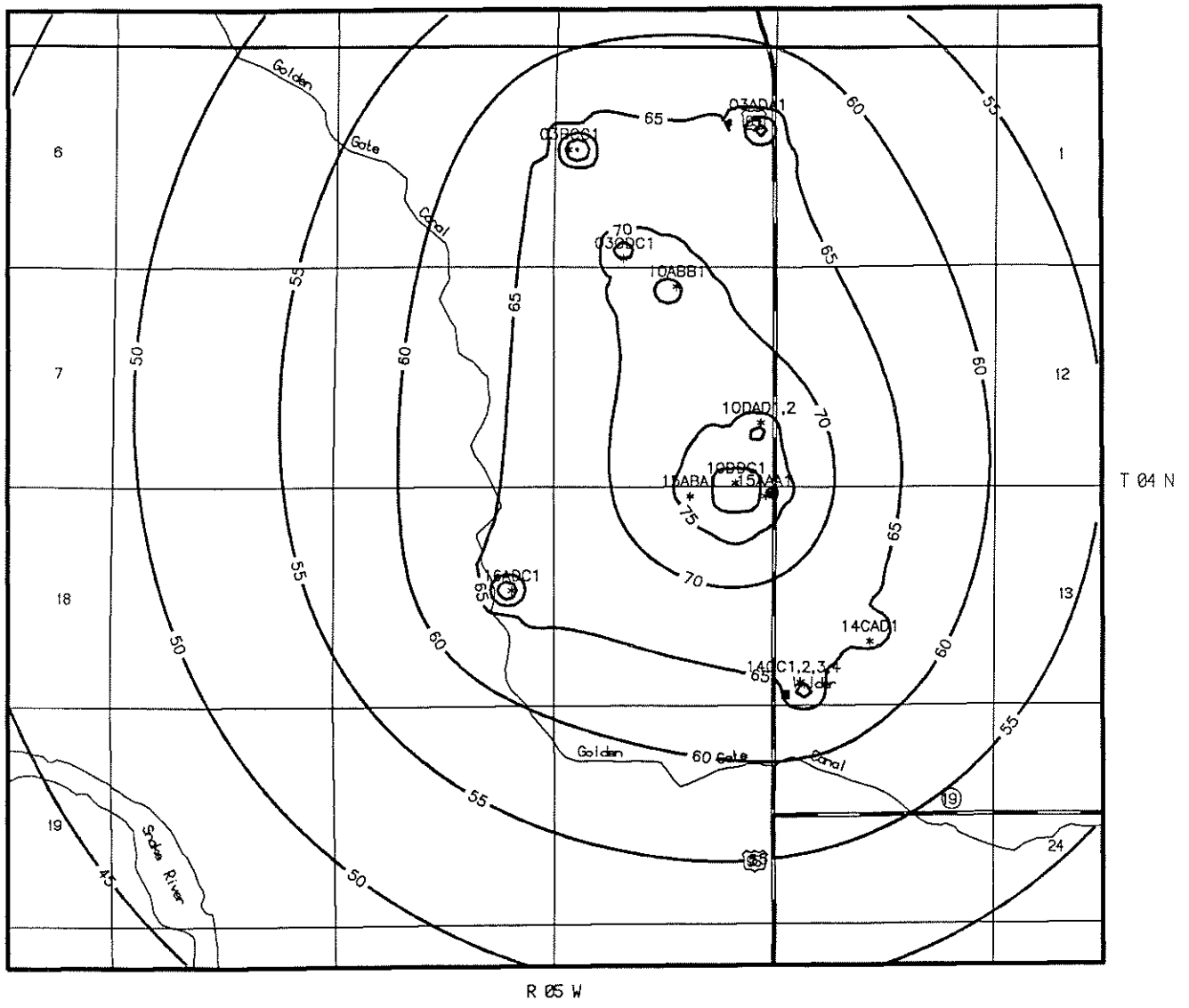

Figure 5. DRAWDOWN DISTRIBUTION FOR SIMULATION #2

SOUTHWEST CANYON COUNTY

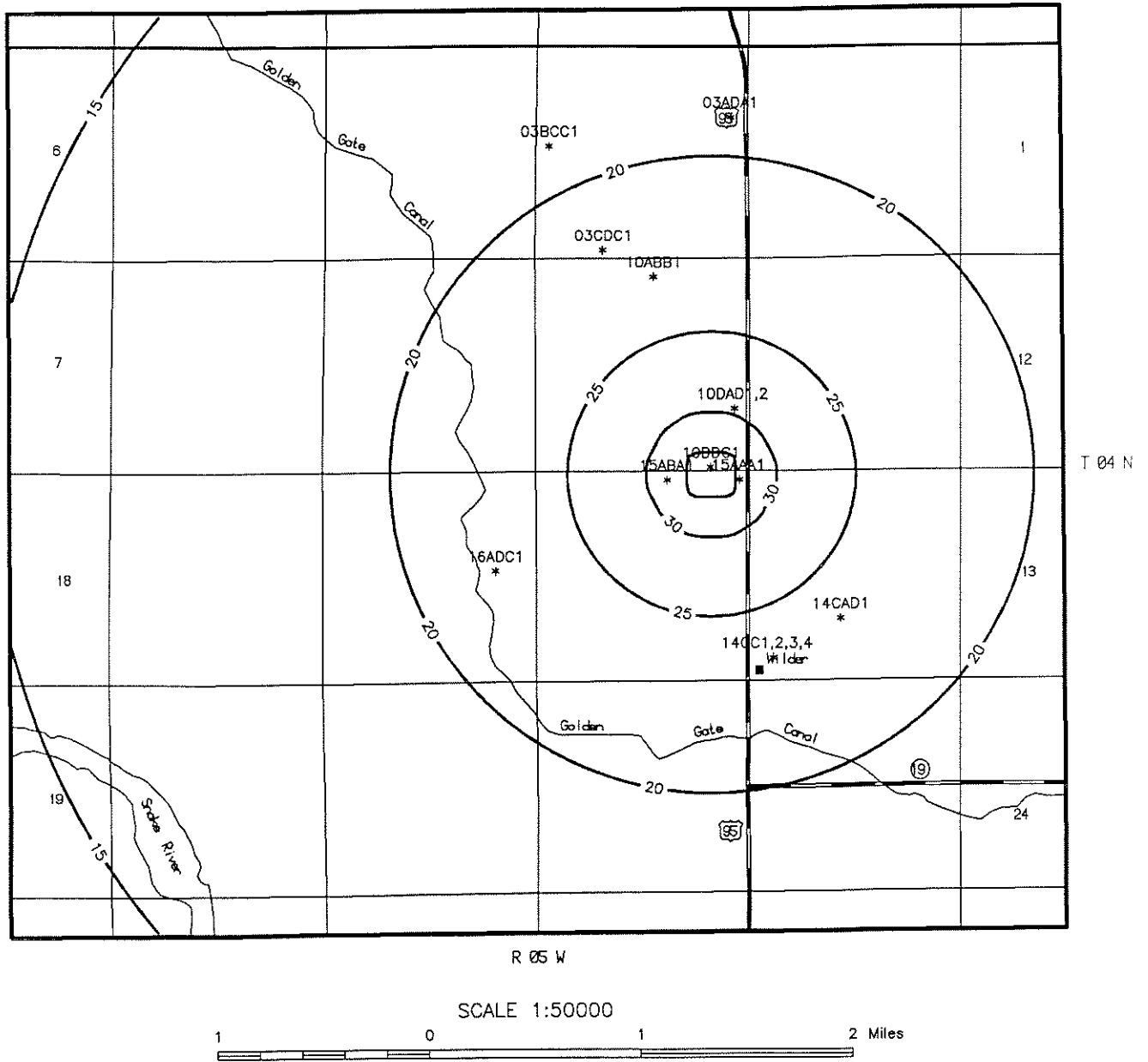

Figure 6. DRAWDOWN DIFFERENCE BETWEEN SIMULATIONS #1 AND #2

Table 3. Parameters used in well interference simulations

Water right number: A - Application; L - Licensed; P - Permit. Use of water: H - Domestic; I - Irrigation; I_s - Irrigation (supplemental use); N - Industrial; P - Public Supply. Average discharge rate: estimated from water right data.

Well number(s)	Well owner	Water right number(s)	Use of water	Average discharge rate (gpm)	Simulation(s)
04N-05W-03ADA1	Rim Ranches	63-08531(L)	I _s	413	1 / 2
03BCC1	Gooding Farms	63-10465(L) 63-10580(P)	I _s	498	1 / 2
03CDC1	Yoshie Yamada	63-08567(L)	I _s	247	1 / 2
10ABB1	Gooding Farms	63-10579(P)	I _s	269	1 / 2
10DAD1,2	SSI Food Services	63-10727(L) 63-11254(P)	I/N	211	1 / 2
10DDC1	Rim Ranches	63-11474(P) 63-11551(A)	I _s	1258	2
14CAD1	Phil Church	63-20543(A)	I	153	1 / 2
14CC1,2,3,4	City of Wilder	63-08164(A)	I/P	265	1 / 2
15AAA1	Hetrick	--	H	--	--
15ABA1	Hetrick	--	H	--	--
16ADC1	Wilder Farm's	63-08649(L)	I _s	476	1 / 2

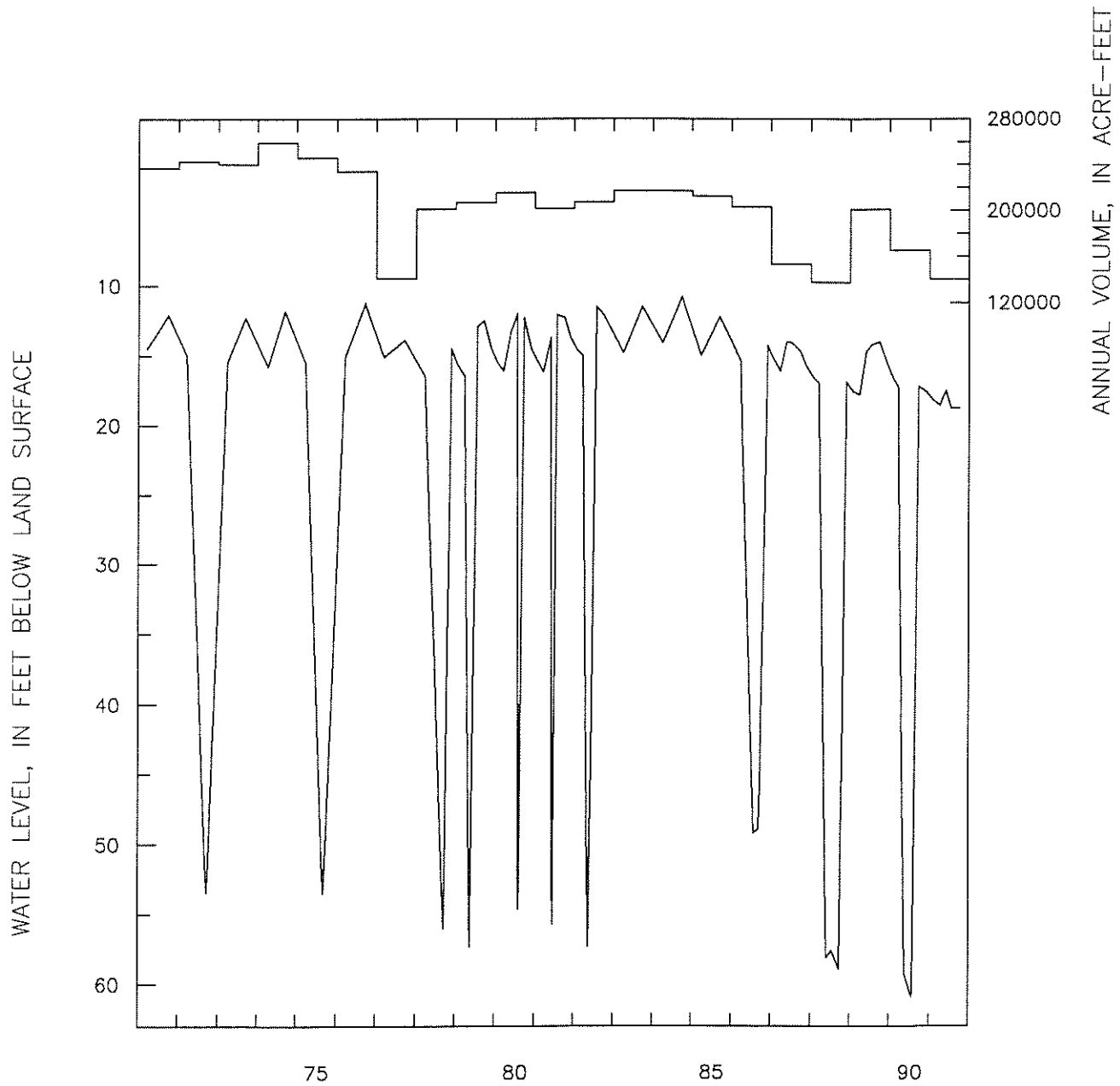

Figure 7. HYDROGRAPHS OF WELL 04N-05W-07DCD1 AND DEER FLAT LOW-LINE CANAL

CONCLUSIONS

Based on the relatively low hydraulic properties computed from the aquifer test, it appears that short-term well interference is a significant problem in the area. Any further ground-water development in the area will undoubtedly accentuate the effects of interference between wells.

According to long-term water level trends in the area, it appears that the local ground-water resources are not currently being overdeveloped. That is, the current annual discharge rate for the area does not appear to exceed the long-term annual recharge rate. However, the effects of further development of the aquifer system are uncertain and continued monitoring of water levels in the area is essential.